

Tool System

刀具系統

VDI Tool Holder System

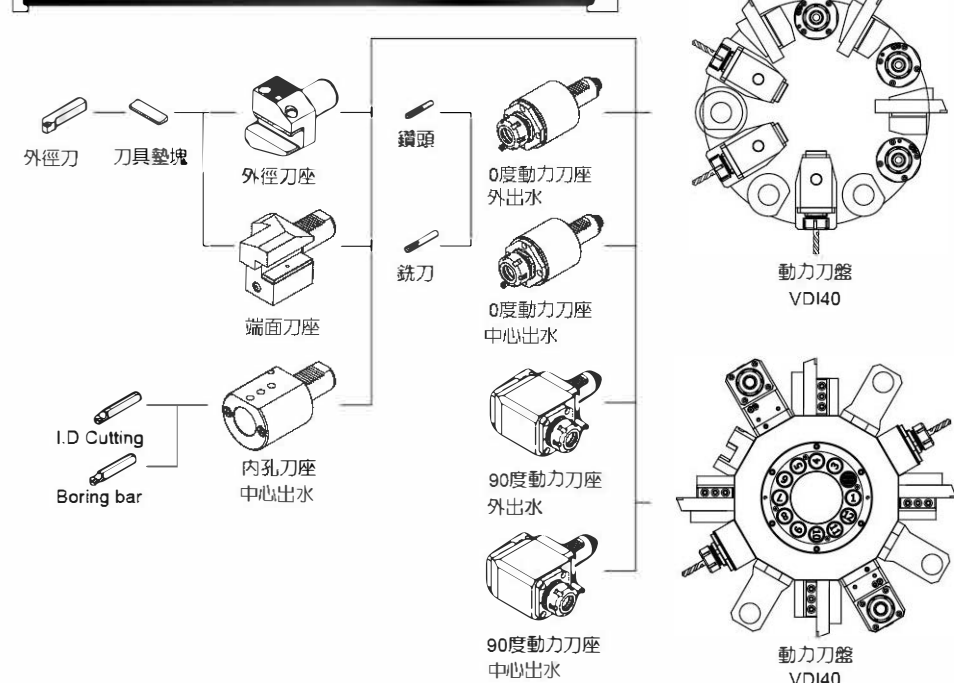

BMT Tool Holder System

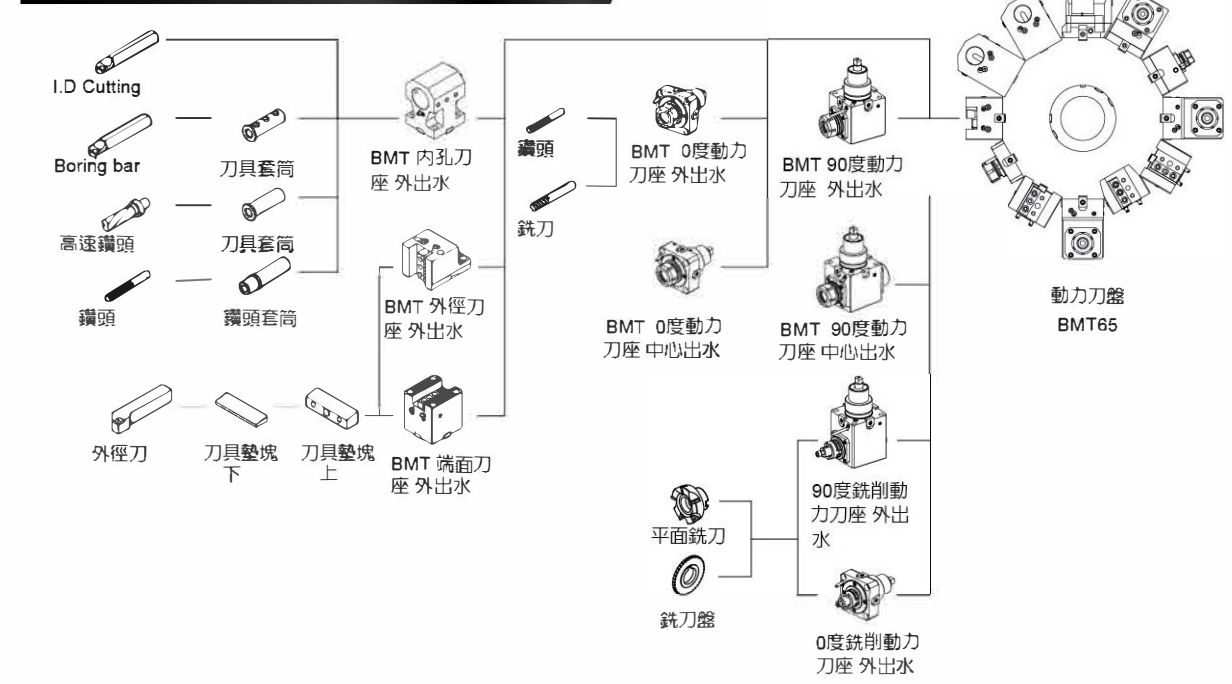

Working capacity 刀具加工範圍(徑向)

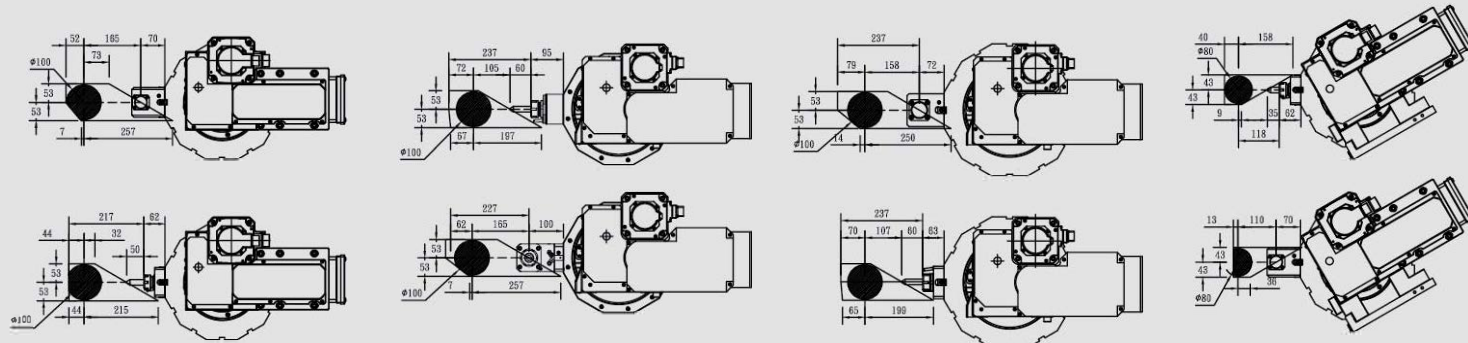

AEGIS

機 型	FTC-15M	FTC-15MY	FTC-23BM	FTC-26BM	FTC-30BM	FTC-23LM	FTC-26LM	FTC-30LM	FTC-23BMY	FTC-26BMY	FTC-30BMY	FTC-23LMY	FTC-26LMY	FTC-30LMY		
床台最大旋徑	Ø540mm	Ø870mm	Ø600mm	Ø600mm	Ø650mm	Ø600mm	Ø600mm	Ø650mm	Ø600mm	Ø600mm	Ø650mm	Ø600mm	Ø600mm	Ø650mm		
床鞍最大旋徑	Ø340mm	Ø630mm	Ø350mm	Ø350mm	Ø420mm	Ø350mm	Ø350mm	Ø420mm	Ø360mm	Ø360mm	Ø440mm	Ø360mm	Ø360mm	Ø440mm		
兩頂心距離	380mm	389mm	588/888/1188mm	583/883/1183mm	583/883/1183mm	604/904/1204mm	599/899/1199mm	599/899/1199mm	574/874/1174mm	569/869/1169mm	569/869/1169mm	549/849/1149mm	544/844/1144mm	544/844/1144mm		
標準加工徑	Ø200mm							Ø230mm								
最大車削直徑	Ø240mm	Ø220mm	Ø290mm							Ø300mm						
最大加工長度	311mm		520/820/1120mm	515/815/1115mm	515/815/1115mm	500/800/1100mm	495/895/1195mm	495/895/1195mm	509/809/1109mm	504/804/1104mm	504/804/1104mm	483/783/1083mm	478/778/1078mm	478/778/1078mm		
主軸馬達功率	9/11kw	9/11kw	11/15kw	15/18.5kw	15/18.5kw	11/15kw	15/18.5kw	15/18.5kw	11/15kw	15/18.5kw	15/18.5kw	11/15kw	15/18.5kw	15/18.5kw		
主軸最高轉速	4200rpm	4200rpm	4200rpm	3200rpm	3000rpm	4200rpm	3200rpm	3000rpm	4200rpm	3200rpm	3000rpm	4200rpm	3200rpm	3000rpm		
主軸鼻端型式	A2-6		A2-6	A2-8	A2-8	A2-6	A2-8	A2-8	A2-6	A2-8	A2-8	A2-6	A2-8	A2-8		
主軸通孔徑	Ø62mm(75OPT)		Ø62mm(75OPT)	Ø92mm(105OPT)	Ø92mm(105OPT)	Ø62mm(75OPT)	Ø92mm(105OPT)	Ø92mm(105OPT)	Ø62mm(75OPT)	Ø92mm(105OPT)	Ø92mm(105OPT)	Ø62mm(75OPT)	Ø92mm(105OPT)	Ø92mm(105OPT)		
棒材最大加工直徑	Ø52mm(65OPT)		Ø52mm(65OPT)	Ø75mm(92OPT)	Ø75mm(92OPT)	Ø52mm(65OPT)	Ø75mm(92OPT)	Ø75mm(92OPT)	Ø52mm(65OPT)	Ø75mm(92OPT)	Ø75mm(92OPT)	Ø52mm(65OPT)	Ø75mm(92OPT)	Ø75mm(92OPT)		
主軸前端軸承直徑	Ø100mm	Ø110mm	Ø100mm	Ø130mm	Ø130mm	Ø100mm	Ø130mm	Ø130mm	Ø100mm	Ø130mm	Ø130mm	Ø100mm	Ø130mm	Ø130mm		
尾座心軸直徑	MT#4		MT#4/MT#5(OPT)	MT#4/MT#5(OPT)	MT#5	MT#4/MT#5(OPT)	MT#4/MT#5(OPT)	MT#5	MT#4/MT#5(OPT)	MT#4/MT#5(OPT)	MT#5	MT#4/MT#5(OPT)	MT#4/MT#5(OPT)	MT#5		
尾座心軸直徑	Ø80mm		Ø80mm	Ø80mm	Ø100mm	Ø80mm	Ø80mm	Ø80mm	Ø100mm	Ø80mm	Ø80mm	Ø100mm	Ø80mm	Ø100mm		
尾座心軸行程	70mm	70mm	70mm	80mm	80mm	70mm	80mm	80mm	70mm	80mm	80mm	70mm	80mm	80mm		
X軸行程	190mm		198mm		205mm							220mm				
Z軸行程	355mm		560/860/1160mm	555/855/1155mm	555/855/1155mm	540/840/1140mm	535/835/1135mm	535/835/1135mm	550/850/1150mm	545/845/1145mm	545/845/1145mm	525/825/1125mm	520/820/1120mm	520/820/1120mm		
Y軸行程	±40mm		±50mm													
ZS軸行程	(580/880/1180mmOPT)															
X軸快速位移速度	20m/min							(B:)20m/min / (L:) 24m/min								
Z軸快速位移速度	20m/min							(B:)20m/min / (L:) 24m/min								
Y軸快速位移速度	15m/min		15m/min													
ZS軸快速位移速度	(B:)20m/min / (L:) 24m/min															
最小輸入單位	0.001mm		0.001mm									0.001mm				
動力刀馬達功率	2.2/3.7kw							3.7/5.5kw								
動力刀具最高回轉數	4000 rpm							4000 rpm								
動力刀座型式	BMT55(VDI-40 OPT)							BMT65(VDI-40 or VDI-50OPT)								
刀柄尺寸	25mm							25mm								
擋孔刀最大尺寸	32mm							40mm								
刀塔刀具數	12 tools							12 tools								
相鄰刀換刀時間	0.4sec							0.47sec								
機器尺寸	3340x1700x1700mm	3519x1678x2035mm	3884x1885x1860mm	3884x1885x1860mm	3884x1885x1860mm	3884x1885x1860mm	3884x1885x1860mm	3884x1885x1860mm	3884x1885x2150mm	3884x1885x2150mm	3884x1885x2150mm	3884x1885x2150mm	3884x1885x2150mm	3884x1885x2150mm		
機器重量	3600kg	3850kg	5100kg	5250kg	5350kg	5100kg	5250kg	5350kg	5300kg	5450kg	5550kg	5300kg	5450kg	5550kg		

B: Box way L: Linear Guide way

FIRST CHANT
凡仕成企業有限公司



車銑複合式

多功能車床



FIRST CHANT
凡仕成企業有限公司
42148 台灣·台中市后里區舊社路3-18號
TEL:+886-4-2559-0525 FAX:+886-4-2559-0387
WEB: www.first-chant.com E-MAIL: fce@first-chant.com

ISO 9001
TAF
Quality Management
QC001

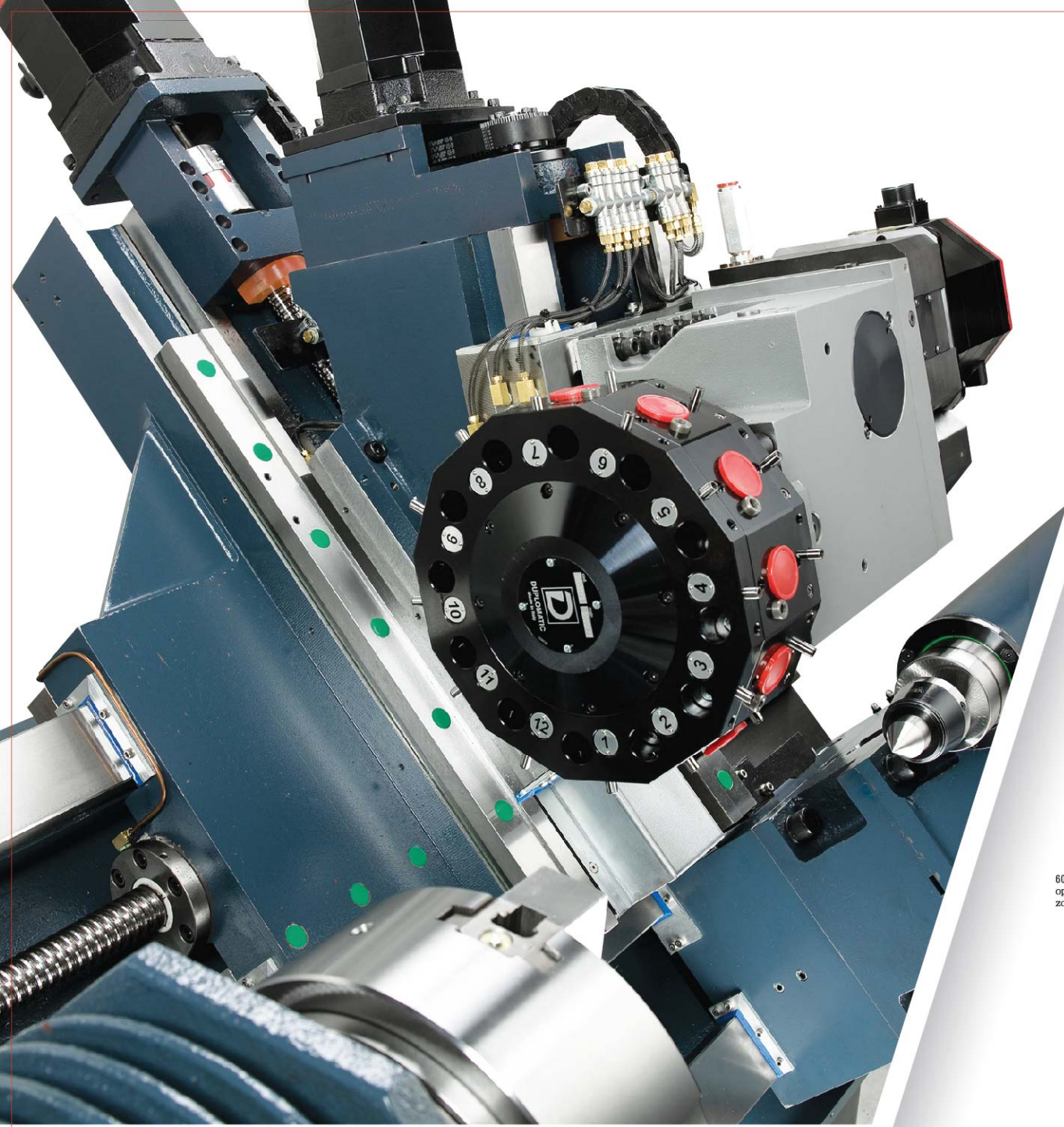

凡仕成斜背式數值控制車床，是高剛性、高精度車銑多功能車床，全系列配置12工位動力刀塔與主軸C軸功能相結合，提供客戶在單機上可完成車削、銑削、搪孔、鑽孔與攻牙等複合加工。

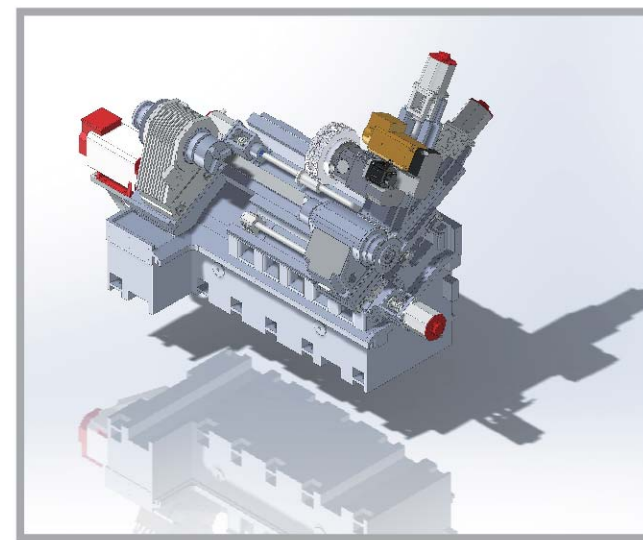

可選擇性控制器



Tool 刀具干涉 Interference

FTC-15MY Tool Interference

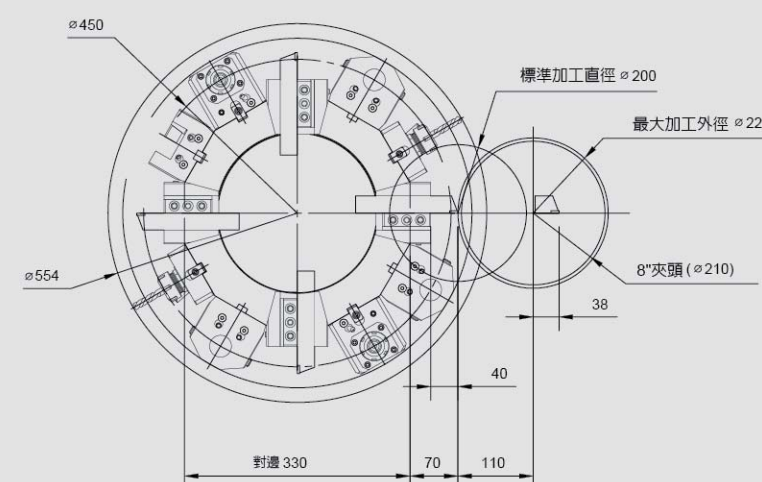

主軸馬達配備廣域高扭力馬達，能在較低轉速作業區間提供重切削能力。

MODEL β iP 18/6000

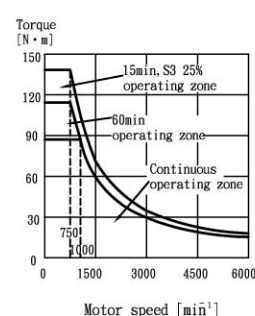
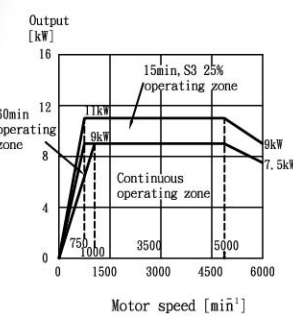

MODEL β iP 22/6000

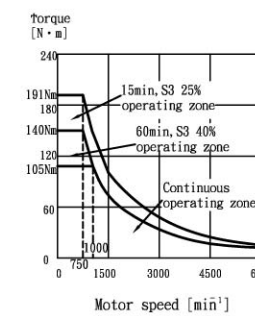
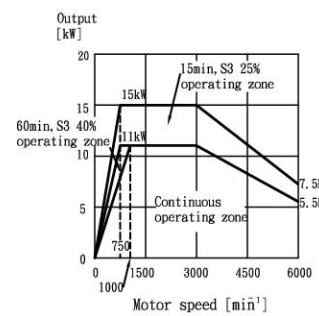

MODEL β iP 30/6000

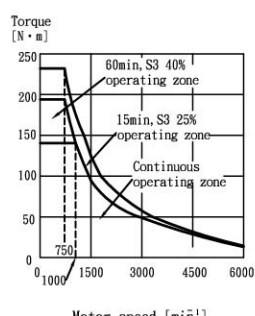
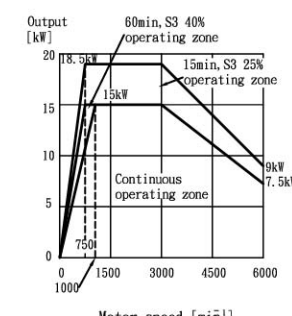

MODEL α 40/6000rP

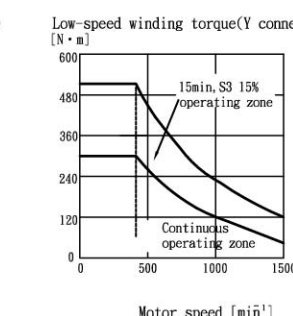
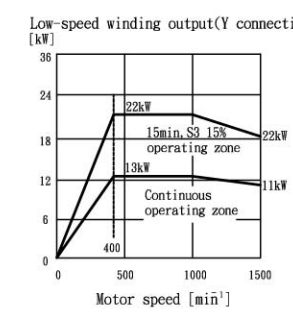

(12T)VDI40-320

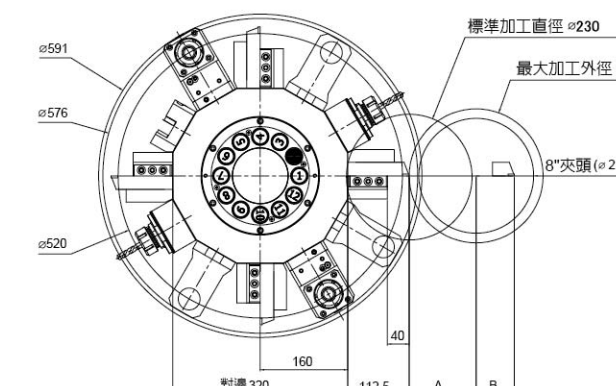

VDI40	單位	A	B	C
FTC-238MY	mm	140	102	280
FTC-238LM	mm	140	102	280
FTC-268MY	mm	140	102	280
FTC-268LM	mm	140	102	280
FTC-308MY	mm	140	102	280
FTC-308LM	mm	140	102	280

(12T)VDI-40-PCD370

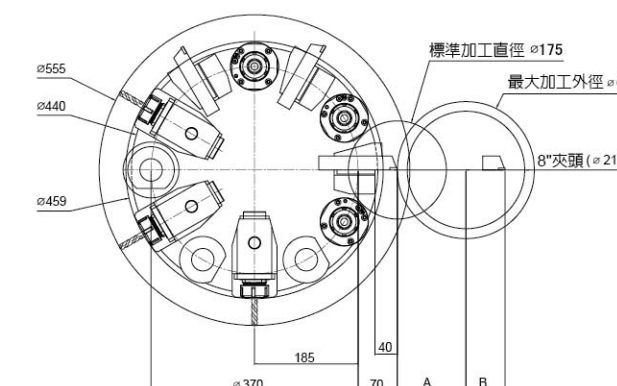

VDI40	單位	A	B	C
FTC-238M	mm	148	92	296
FTC-238L	mm	152	60	304
FTC-268M	mm	148	92	296
FTC-268L	mm	152	60	304
FTC-308M	mm	148	92	296
FTC-308L	mm	152	60	304



主軸搭配C軸功能，使得機械可以達到千分之一度進行輪廓加工。

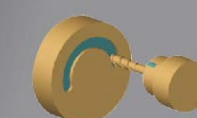

C-Axis Machining



X-C Axis Machining

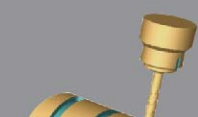

Z-C Axis Machining

高剛性結構

一體式床身由高品質米漢納鑄鐵製成，經過應力消除，使得機身可長久保持不變形。

高剛性大型床身和底座結構，具有優良的減震效果硬軌厚度增加30%，使得剛性更佳。

線軌機型採用：日本品牌Tsubaki線性滑軌磨擦力小，確動性佳，主要應用在高精度加工要求。

複合式車床提供最佳性能

配備Y軸及動力刀塔，+/- 40mm或+/-50mm行程可提供螺紋銑削，複雜的偏心銑削和鑽孔的加工。

Y軸設計是由兩個獨立滑座的同時移動來實現，此種設計經由兩個獨立滑座上分配切削力，確保出絕佳的剛性和精度。

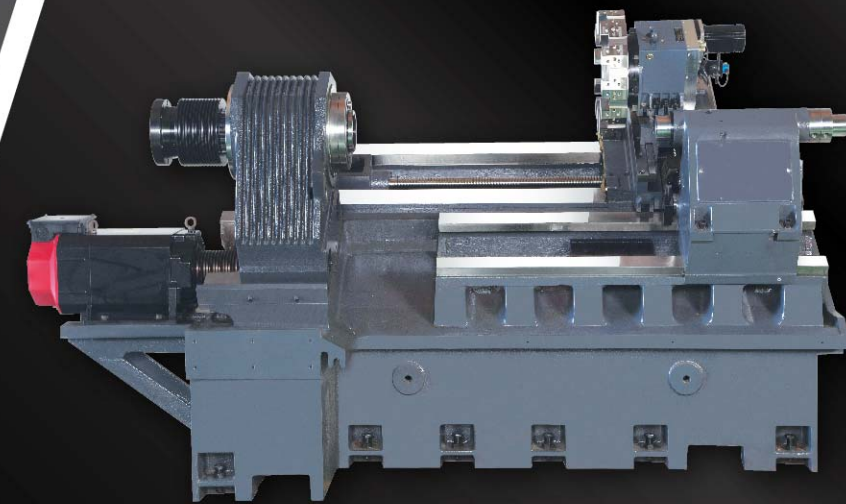

(12T)BMT55-330

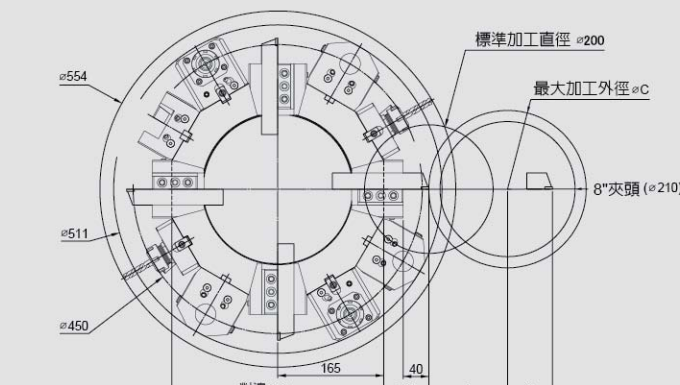

BMT55	單位	A	B	C
FTC-15M	mm	120	70	240
FTC-238M	mm	165	60	330
FTC-238LM	mm	153	52	306
FTC-268M	mm	165	60	330
FTC-268LM	mm	153	52	306
FTC-308M	mm	165	60	330
FTC-308LM	mm	153	52	306

(12T)BMT65-380

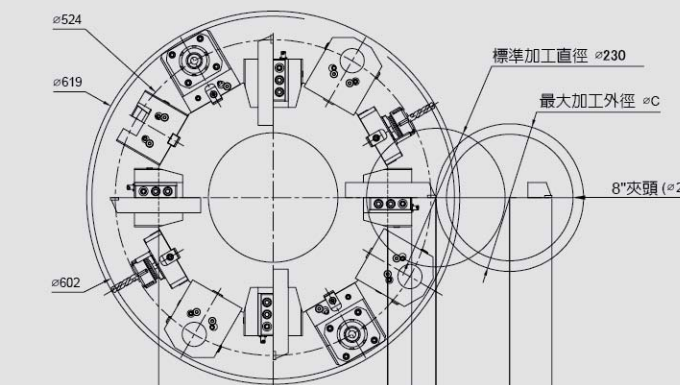

BMT65	單位	A	B	C
FTC-238M	mm	145	60	290
FTC-238LM	mm	149	56	298
FTC-268M	mm	145	60	290
FTC-268LM	mm	149	56	298
FTC-308M	mm	145	60	290
FTC-308LM	mm	149	56	298